

Macchine automatiche per il riempimento e la chiusura dei tubetti.  
Automatic tube filling and sealing machines.

**T 150**

Fino a 11.000 pezzi/ora  
*Up to 11.000 units/hour*



# Caratteristiche tecniche

Technical characteristic

Caracteristiques techniques

Technische eigenschaften

Características técnicas

## T 150



Le descrizioni e fotografie di questo catalogo sono indicative e possono essere modificate senza alcun preavviso.

Descriptions and pictures of this brochure are given for information only and can be modified without prior notice.

Les descriptions et illustration sont indicatives et peuvent être modifié sans préavis.

Las descripciones del presente catalogo son solo indicativas y pueden ser modificate sin noticia.

Beschreibungen und Abbildungen in diesem Katalog sind unverbindlich und können ohne vorherige Anzeige geändert werden.

Pezzi/ora Fino a **11.000**

Units/hour Up to **11.000**

Pièces/heure Jusqu'à **11.000**

Stück/h Bis zu **11.000**

Pz/hora Hasta **11.000**

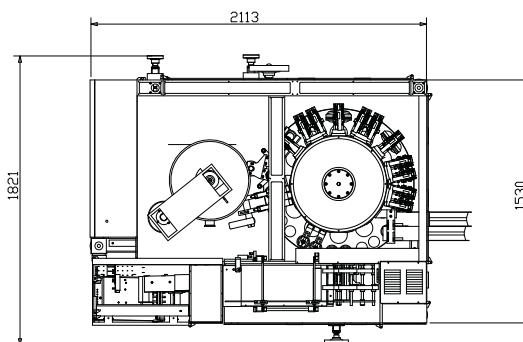
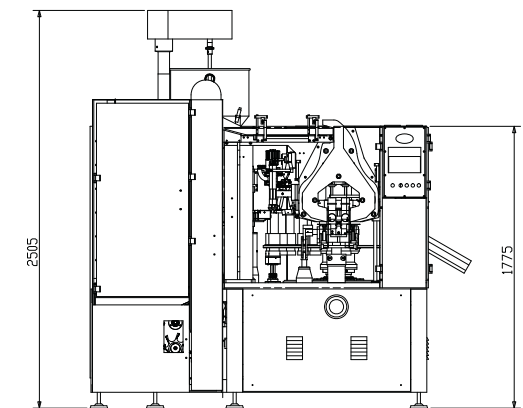

DIMENSIONI TUBI		Metallo	Plastica
Tube size - Type de tubes Tubenart - Tipo de tubos		Metal - Metalliques Metall - Metal	Plastic - Plastiques Kunststoff - Plastico
Diametro		min-max	min-max
Diameter - Diameter Ø - Diametro	mm	10-42	10-50
Lunghezza			
Length - Longueur Länge - Largura	mm	50-240	50-240
Potenza installata			
Power - Puissance installé Inst. Leistung - Potencia installada	kW	5.5	12

CONSUMI		Metallo	Plastica
Consumption - Absorption Verbräuche - Consumos		Metal - Metalliques Metall - Metal	Plastic - Plastiques Kunststoff - Plastico
Acqua		min-max	min-max
Water - Eau Wasser - Agua	l/min	-	1-2
Aria			
Air - Air Luft - Aire	l/min	300	500



**TGM - TECNOMACHINES s.r.l.**

Via delle Industrie, 104 - 24059 URGNANO (BG) Italy - Tel. +39 035 893135 - Fax +39 035 893151 - www.tgm.it - info@tgm.it